



Manual- and installation guide

Instantaneous water heater CDE-L 11-15 LCDSelect
Instantaneous water heater CDE-L 18-24 LCDSelect



GB

Keep this installation guide

Edition:04/15

Id_Nr. 911 360 621

1. Important instructions

Before using the heater, please read the instructions carefully. In the future it will benefit by its failure-free operation for a long time.

Flow water heaters series LCDSelect are intended for heating tap water. They can supply hot water to several water outlets located in different rooms. These heaters are equipped with heating coils which are directly washed by water. Such direct process of heating prevents scale formation and ensures high efficiency and speed of heating water. The microprocessor system analyses the temperature of inlet and outlet water, the set temperature, and water consumption of the user. Based on the collected data, it increases or decreases the heating power in such a way that the water temperature at the outlet corresponded to the temperature set by the user. Such control of the heater operation ensures the comfort of use and energy saving. Additionally, the heater is equipped with the possibility of choosing rated power. It is equipped with air lock sensors which limit, to the minimum, the possibility of damage of the heating elements due to air locking of the water distribution system, as well as the system adjusting the temperature drop caused by the drop of supply voltage.

Heaters can additionally heat water that was pre-heated, e.g. with the use of the solar system which at the heater inlet cannot exceed 60°C.

- **The device cannot be installed in rooms in which the temperature may fall below 0°C and in which there is the risk of explosion.**
- **This equipment is not intended to be used by persons (including children) of lower physical, sensory or mental capability, unless they operate it under supervision.**
- **Attention should be paid to children not playing with the equipment.**

The installation and start-up of the LCDSelect heater should be done by a person qualified in accordance with the guidelines contained in the Manual. All installation works should be carried out with disconnected power and water supplies. The heater electrical installation should be conducted in accordance with the binding regulations. The device should be permanently connected to electrical wiring with ground terminal. The electrical wiring should be equipped with residual current circuit breaker protecting against electric shock and with a switch ensuring the disconnection of the device from the power source, in which the distance between the contacts should be not less than 3 mm.

2. Installation instruction

1. To the place in which the heater is to be installed lead electrical wiring and water distribution system, using for that the mounting template.
2. Drill holes and mount expansion plugs.
3. Install the control valve with a filter on cold water supply (Fig. 3).
4. Unscrew the fastening screw which holds the housing of the heater located at the bottom of it (Fig. 1), take off the cover and disconnect the ribbon cable by taking the plug out of the socket marked "LCD" (Fig. 2).
5. Select rated power by transferring the link to a proper place on a contact marked MOC according to the description on the sticker.
6. Screw the heater to the wall with the use of fastening screws, having earlier run the power cable through the hole.
7. Check the starting of pressure switch.
8. Remove the securing blanking plugs from water pipes.
9. Connect the heater to the water distribution system (Fig. 5 service line marked 14, outlet marked 15)
10. Switch on the water supplying the heater and check the tightness of the connections.
11. Connect the heater to the electrical wiring in accordance with Figure 4.
12. Connect the ribbon cable by inserting the plug with the proper side to the socket marked "LCD", see (Fig. 2).
13. Put on the housing and screw it with a fastening screw.

Manual- and installation guide LCDSelect

GB

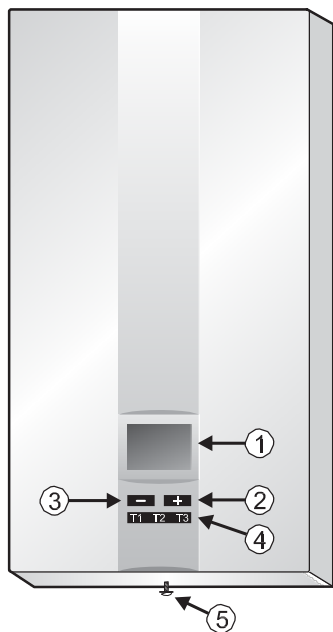

Fig. 1. Heater housing

- 1) Display
- 2) Button increasing the set temperature
- 3) Button decreasing the set temperature
- 4) Memory buttons of the set temperature
- 5) The screw fastening the housing

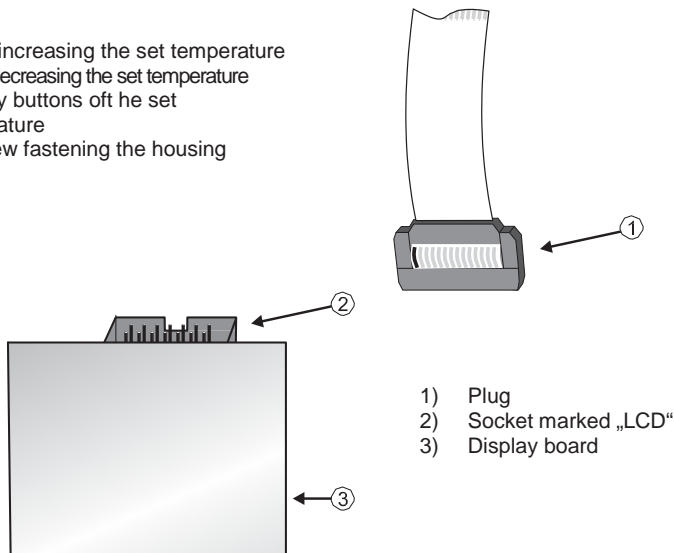
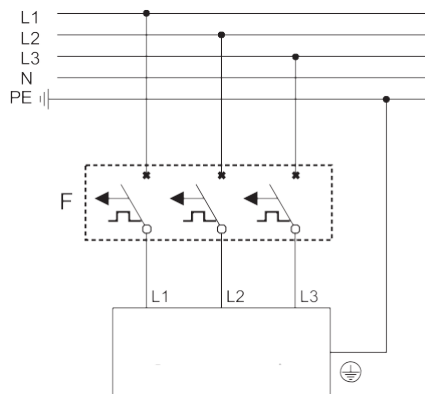
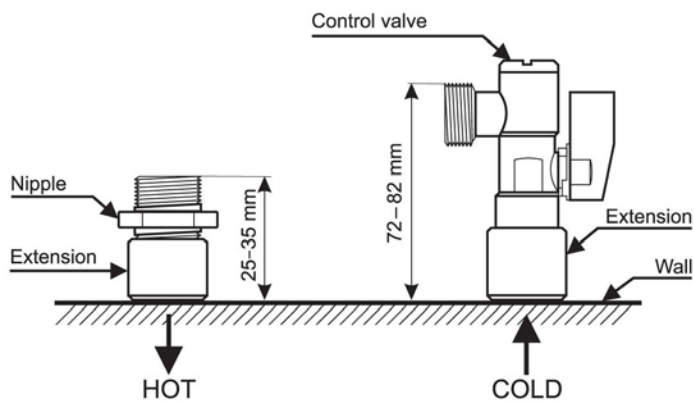

Fig. 2. Display board with ribbon cable

Fig. 3



3. Starting

In order to remove air from the water distribution system and the heater, before turning the power on, open the hot water valve for approx. 20 seconds in order to remove air bubbles from the system. Then, turn the power on. Open the hot water valve waiting till the device has achieved full operational readiness (approx. 5 seconds) beginning the process of heating – in the lower part of display lines will be shown indicating (in percent) the heating power of the heater. Close the hot water valve. The heating process is automatically turned off – the lines previously indicating the heating power will disappear from the display.

Manual- and installation guide LCDSelect

4. Use

Setting the temperature of water is done by pressing one of the buttons located under the display marked “-” and “+ ” (Fig. 1) in the range from 30°C to 60°C accurate every 0.50C. Detecting the flow greater than 2.7 l/min by the heater system will result in switching off the device. The lines of the barograph (lower part of the display) show the power with the heater heats the water. The appearance of one line means the heater is heating with the power not smaller than 10% and not greater than 20% of the rated power. The appearance of five lines means the heater is heating with the power not smaller than 50% and not greater than 60% of the rated power. The appearance of all ten lines means the heater is heating with full power. The signaling by the heater that it is heating with full power is the information for the user to decrease the consumption of water or decrease the set temperature because the power of the device at a given moment is not small to heat up water to the desired temperature. After each start or change of the set temperature, the heater measures temperature of outlet water every 10 seconds. If two temperature measurements are the same it means the temperature has stabilized and the electronic system can compare it with the set temperature. In case when the obtained temperature is smaller from the set temperature due to the drop of the mains voltage, the heater increases the power automatically, so that the water temperature achieved the desired value.

In case when the inlet temperature exceeds 55°C, the heater will turn off till the moment when the temperature of supply water will fall below 55°C.

Hot water capacity (in litres per minute) depending on the temperature of inlet water and the selected power for heater LCDSelect18/21/24

Water temperature at the inlet	Water temperature at the outlet					
	40°C			50°C		
	11 kW	13,5 kW	15 kW	11 kW	13,5 kW	15 kW
5°C	4,5	5,5	6,2	3,5	4,3	4,8
10°C	5,3	6,5	7,2	3,9	4,8	5,4
15°C	6,3	7,8	8,7	4,4	5,5	6,2

Hot water capacity (in litres per minute) depending on the temperature of inlet water and the selected power for heater LCDSelect11/13,5/15

Water temperature at the inlet	Water temperature at the outlet					
	40°C			50°C		
	18 kW	21 kW	24 kW	18 kW	21 kW	24 kW
5°C	7,4	8,7	9,9	5,8	6,7	7,7
10°C	8,6	10,1	11,6	6,5	7,6	8,7
15°C	10,4	12,1	13,9	7,4	8,7	9,9

5. Programming the buttons T1, T2, T3

The heater can save three values of temperatures selected by the user. To save, as well as select temperatures the buttons marked T1, T2, T3 are used. In order to assign the temperature value to any of the buttons (T1, T2, T3):

1. Set the desired temperature on the display by pressing “-” or “+”
2. Hold down any of the selected buttons (T1, T2, T3) for approx. 4 seconds till the moment when the digits on the display will go out for a moment signaling by that that the value of the temperature set on the display has been assigned to the memory of the pressed button.

After short pressing of any of the buttons (T1, T2, T3), the programmed temperature will be displayed, and thereby the set temperature with which the heater is to heat the water. In order to re-program any of the buttons (T1, T2, T3), follow the instructions given in points 1 and 2.

6. Display service mode

The simultaneous pressing of buttons marked “-” and “+” for about 1 second will make the display shift from the basic mode (the information about the set temperature and power is displayed) to the service mode enabling to show such data as:

- flow rate
- inlet water temperature
- outlet water temperature
- installed power
- staring additional sensors (air lock sensors)

In the service mode the display shows different data for approx. 3 separating them by shortly displaying “0.0”. After displaying the last piece of data, the display automatically shifts to the basic mode

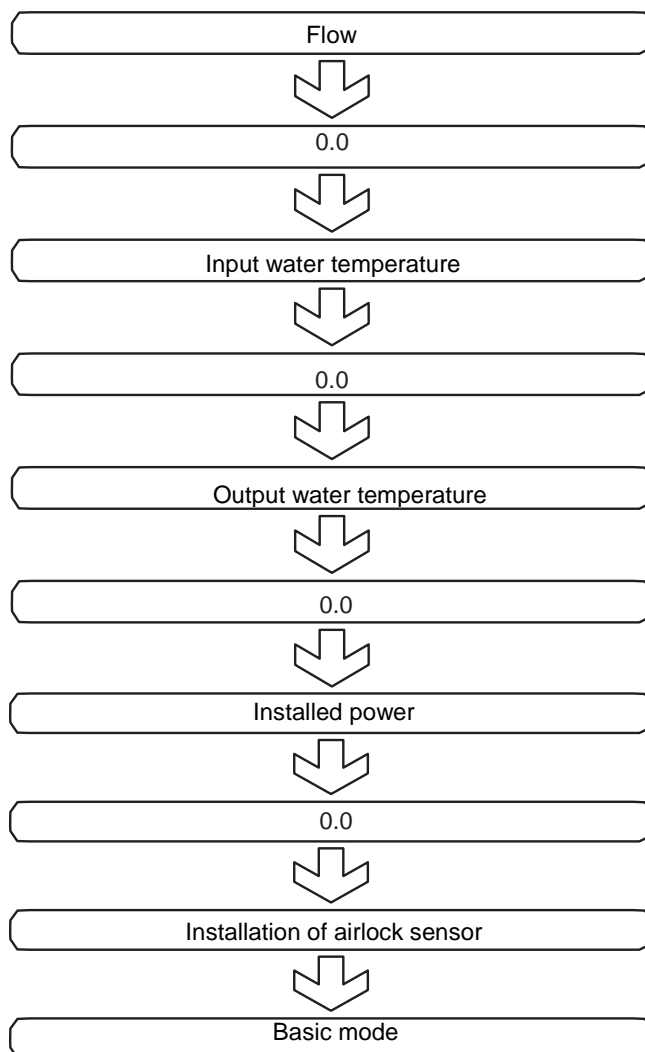

7. Cleaning the water filter

In a situation when the filter has become fully or partially blocked:

1. Disconnect the power supply.
2. Unscrew the fastening screw located at the bottom of the housing (Fig. 1), then take off the housing holding it at such a distance from the heater that the ribbon cable connecting the display with the heater was not tightened, and then disconnect the cable by plugging it out of the socket marked "LCD" (Fig. 2).
3. Close the control valve (marked 1).
4. Unscrew the control valve plug (marked 2).
5. Take out the mesh filter (marked 3).
6. Remove dirt.
7. Insert the mesh filter.
8. Screw the valve plug.
9. Open the control valve and check the tightness of connections.
10. Connect the ribbon cable of the display board (Fig. 2).
11. Close the housing.
12. Remove entrapped air from the heater, and then start it in accordance with chapter "Starting".

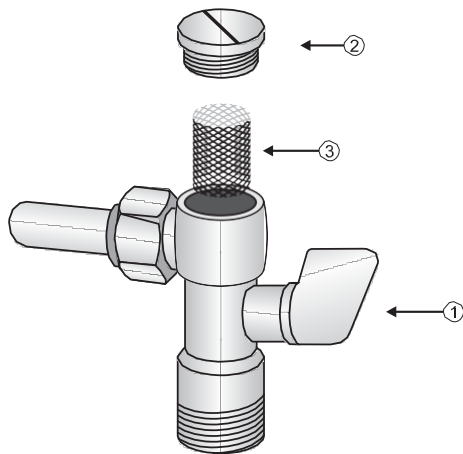

1. Control valve knob (position: flow closed)
2. Valve plug
3. Mash filter

Abb. 5. Control valve with the filter

8. Malfunctioning of the heater

Removing the causes of the malfunctioning of the heater given below is not included in the manufacturer's guaranty. Should none of the following occur, please contact the service point.

Display does not light:

- disconnected ribbon cable connecting the controller board with the display (Fig. 2).
- failure of the electrical wiring powering the heater.

Too small flow of water:

- blocked water filter.
- too small water pressure.
- control valve closed too tightly.
- main valve not completely open.

The heater does not heat or heats poorly:

- wrong hydraulic, failure of the electrical wiring powering the heater.

The heater does not heat the water to the set temperature:

- too big drop of the mains voltage after the start of the heater.
- too big flow of water (see: point "Use").

The display shows the number bigger than or equal to 75.0 – the heater is blocked.

- the heater has an additional thermal protection which works in the following way: when outlet water reaches the temperature equal to or higher than 75°C the electrical system will block. Not until it is turned off and then turned on again after the fall of temperature below 75°C it will unblock. If such a situation occurred due to supplying pre-heated water of the temperature higher than the permissible temperature, it needs to be decreased. In other cases, please contact the service point.

1. Lower housing
2. Upper housing (s. Abb. 1)
3. Display board with keyboard
4. Heating unit
5. Flow switch
6. Air lock sensors
7. Inlet water temperature probe
8. Outlet water temperature probe
9. Outlet water thermal switch
10. Pressure switch
11. Terminals will be parts of the pressure switch
12. Hole for inserting the power cord
13. Controller board
14. Supply water pipe (cold)
15. Outlet water pipe (hot)
16. Protective conductor terminal

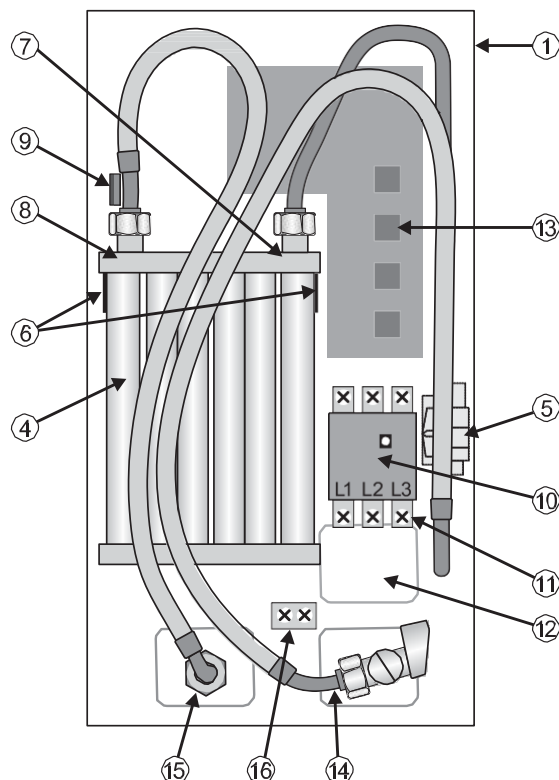

Manual- and installation guide LCDSelect

9. Schematic diagram

1. Thermal switch
2. Display board & keyboard
3. Flow switch (turbine)
4. Inlet water temperature probe
5. Outlet water temperature probe
6. Flow switch
7. Air lock sensor
8. Heating unit
9. Heat controller
10. Pressure switch

PE Protective conductor terminal
E Electrode

G1, G1, G3, G4 – Heating elements

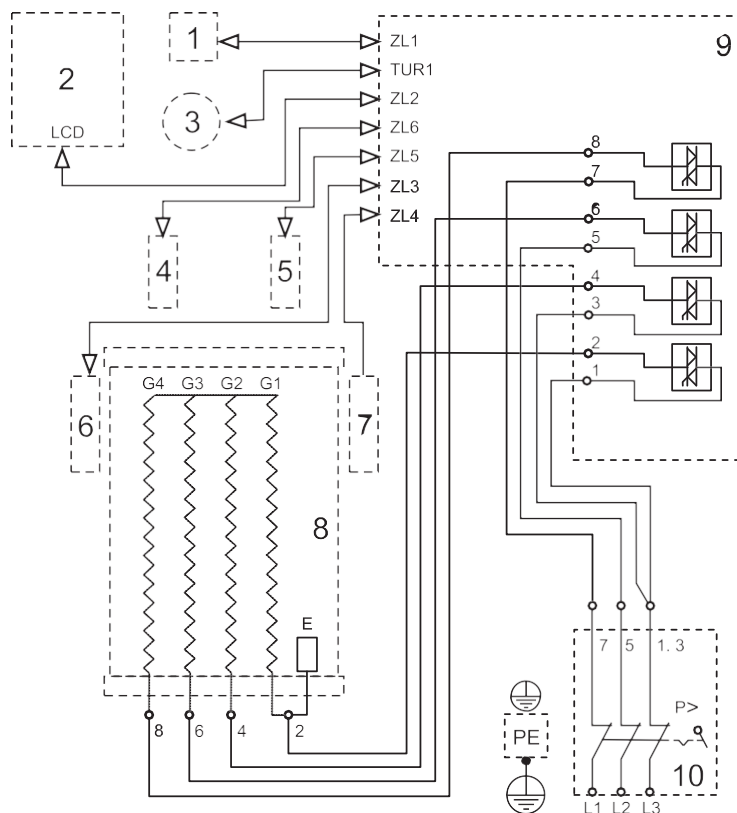

11. Technical data

Model LCDSelect		LCDSelect 11/13,5/15			LCDSelect 18/21/24		
		11	13,5	15	18	21	24
Switching power		Yes					
Rated power	kW	11	13,5	15	18	21	24
Supply voltage		400V 3~					
Frequency	Hz	50					
Power consumption	A	18	19,4	22,2	29	31	35,5
Minimum cross-section of connecting	mm ²	4 x 2,5			4 x 4		4 x 6
Maximum cross-section of connecting	mm ²	4 x 10					
Rated power of the miniature circuit breaker	A	20	20	25	32	32	40
Minimum water resistance at 15°C	Ωcm	1300					
Pressure of the supplying water	MPa	0,1 – 0,6					
Minimum starting flow	l/min	2,7					
Maximum temperature of the supplying water	°C	60					
Water pipe		G ½"					
Dimensions (H x W x D)	mm	447 x 235 x 109					
Weight	kg	3,8					

IMPORTANT INSTRUCTIONS CONCERNING THE DETERIORATED DEVICE

Pursuant to the provisions of the Act dated 29 July 2005 on waste electric and electronic equipment, it is forbidden to put together with municipal waste the deteriorated equipment marked with the symbol of the crossed out bin. A user who intends to get rid of the product, should take the waste electric or electronic equipment to the point collecting the waste equipment. Collection points are run, among others, by wholesalers or retailers of such equipment as well as by gmina organizational units conducting the activity in the scope of collecting waste. The above statutory obligations have been introduced in order to limit the amount of waste created from deteriorated electric and electronic equipment, as well as to ensure the proper level of collecting, recovering and recycling the waste equipment. In the equipment there are no dangerous elements which have a particularly negative effect on health and the environment.

The materials used in the device are re-usable. Thanks to re-use, re-use of materials, or other forms of use of the deteriorated devices, you contribute significantly to the protection of our environment.



TECHNOTHERM support

Fon: +49 (0) 911 937 83 210

Lucht LHZ Elektroheizung GmbH & Co. KG
Obere Hauptstr. 61
09232 Hartmannsdorf
Fon: 03722 63370
Fax: 03722 633720
E-mail: info@technotherm.de
Web: www.technotherm.de